

FEBRUARY 12, 2019

PROPOSED CREAGH STRATEGIC  
HOUSING RESIDENTIAL DEVELOPMENT  
AT BALLOWEN/RAMSFORTPARK, GOREY,  
CO. WEXFORD  
FOR AMIL PROPERTIES LIMITED  
STREETLIGHT SPECIFICATION

## Roadway Report Summary

### Layout

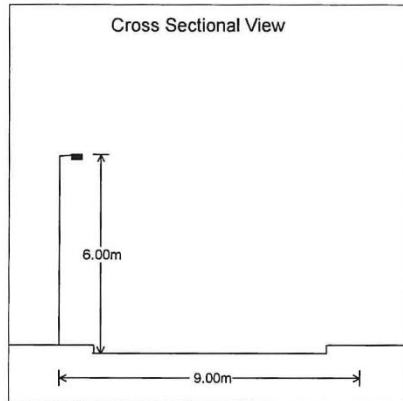

### Road Data

Calculation Grid	2015:EN13201 Illuminance
Width (m)	9.00
No. of Lanes	2
Road Surface	C2
Q0	0.07
Left Footpath (m)	2
Right Footpath (m)	2

### Main Lighting

#### Column Data

Configuration	Single Sided Left
Spacing (m)	32.00
Height (m)	6.00
Tilt (deg)	5.00
Setback (m)	1.00
Outreach (m)	0.50
Overhang (m)	-0.50

#### Luminaire Data

Supplier	Kirium Pro Mini [5mA Steps]
Type	KIRIUM PRO MINI 16LED 4k A1_445mA U MSUG 42 0024 0000 100
Lamp(s)	16 x 4k LED
Lamp Flux (klm)	2.93
File Name	KIRIUM PRO MINI 16LED 4k A1_445mA U MSUG 42 0024 0000 100.ies
Maintenance Factor	0.75
Lum. Int. Class	None

### Results

#### Main

Complies with P4

Eav	5.14
Emin	2.27
Emax	16.50
Emin/Emax	0.14
Emin/Eav	0.44

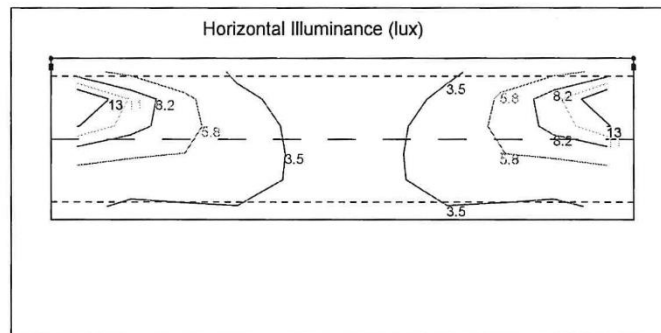

### Polar Diagram

**Main Luminaire KIRIUM PRO MINI 16LED 4k A1 445mA UMSUG 42 0024 0000 100**

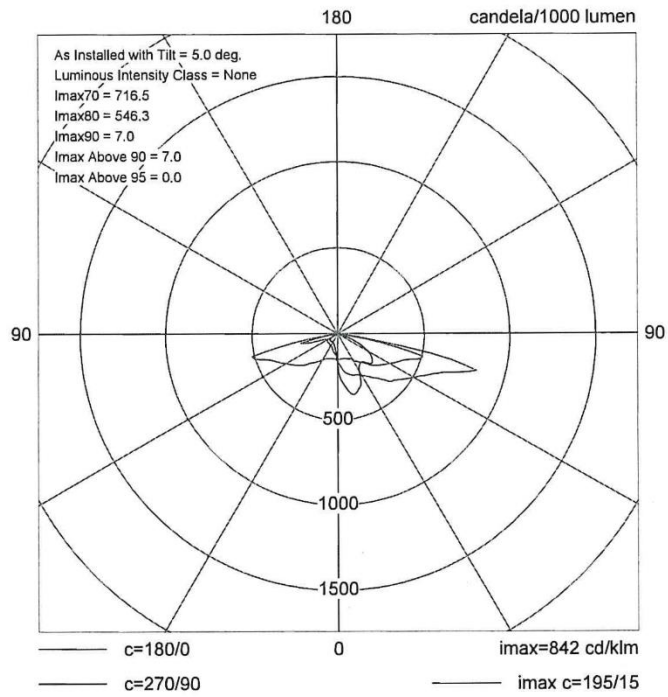

68613523

### Horizontal Illuminance (lux)

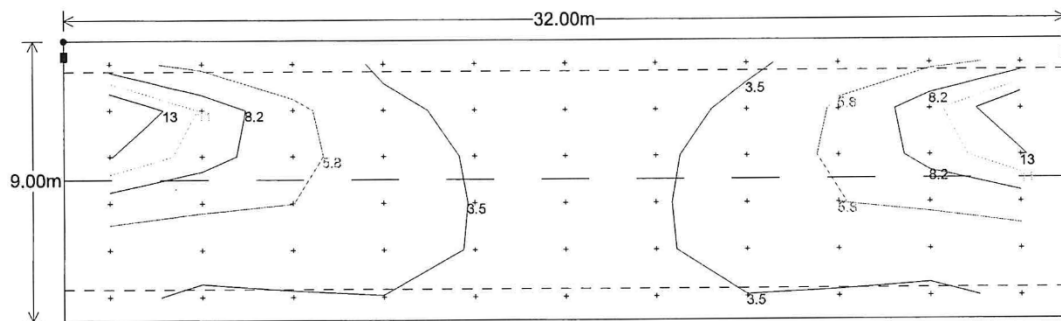

#### Main Results

Eav	5.14
Emin	2.27
E <sub>max</sub>	16.50
Emin/E <sub>max</sub>	0.14
Emin/Eav	0.44

### Horizontal Illuminance (lux)

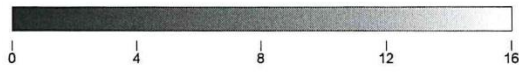
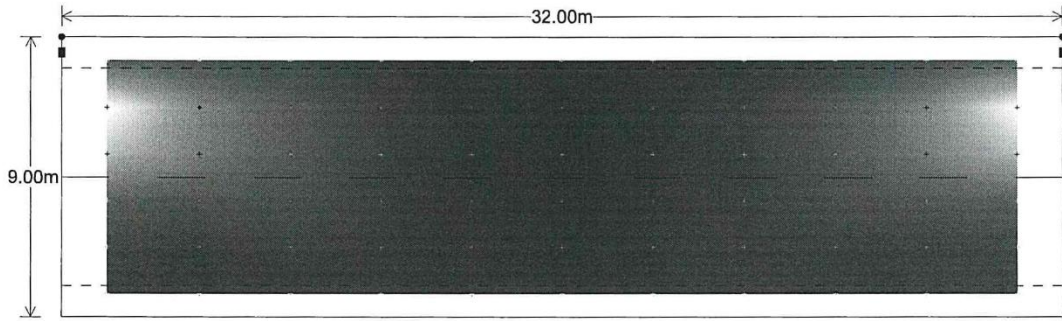

445613203

**Horizontal Illuminance (lux)**

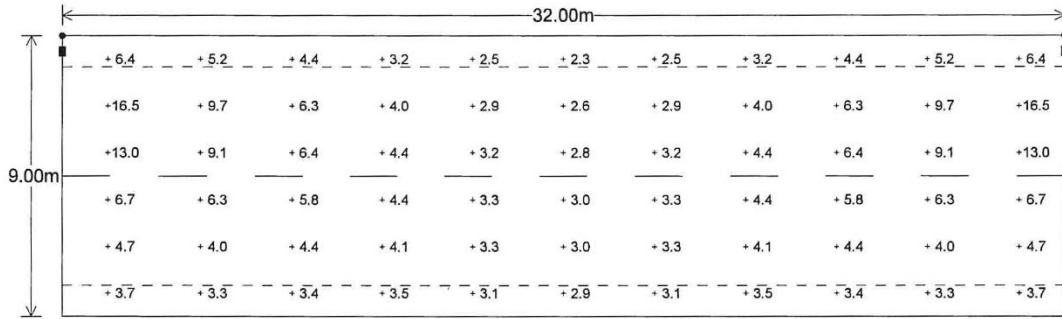

669612525